

3,000-SHEET FINISHER
(Machine Code: B302)

1. OVERALL MACHINE INFORMATION

1.1 SPECIFICATIONS

The punch unit is an option for this machine.

Paper Size: No punch mode
 Shift Tray: A3 to A5/DLT to HLT
 Upper Tray: A3 to A5, A6 lengthwise, B6 lengthwise/
 DLT to HLT
 Punch mode
 2 holes: A3 to A5/DLT to HLT
 3 holes: A3, B4, A4 sideways, B5 sideways
 DLT, LT sideways
 4 holes (Europe): A3 to A5
 DLT to LT, HLT sideways
 4 holes (North Europe): A3 to B5, A5 sideways
 DLT to LT, HLT sideways
 Staple Mode
 A3 to B5/DLT to LT

Paper Weight: No punch mode
 No staple mode: 52 g/m² ~ 216 g/m², 14 ~ 42 lb
 Staple mode: 64 g/m² ~ 80 g/m², 17 ~ 21 lb
 Punch mode
 2 holes: 52 g/m² ~ 163 g/m², 14 ~ 42 lb
 3 holes: 52 g/m² ~ 163 g/m², 14 ~ 42 lb
 4 holes: 52 g/m² ~ 128 g/m², 14 ~ 34 lb

Paper Capacity: Shift tray/no staple mode (80 g/m², 20 lb):

	Punch mode	No punch mode
B5 sideways A4 sideways LT sideways	2,500 sheets	3,000 sheets
Other sizes	1,500 sheets	1,500 sheets

Shift tray/staple mode/punch mode (80 g/m², 20 lb):

	Pages/set	Sets
B5 sideways	2 to 9	150
A4 sideways LT sideways	10 to 80	200 to 30
Other sizes	2 to 9	100
	10 to 40	150 to 30

Options

Shift tray/staple mode/no punch mode (80 g/m², 20 lb):

	Pages/set	Sets
B5 sideways	2 to 9	150
A4 sideways	10 to 100	200 to 30
LT sideways		
Other sizes	2 to 9	150
	10 to 50	150 to 30

Upper tray (80 g/m², 20 lb):

	Punch mode	No punch mode
A4/LT or smaller	400 sheets	500 sheets
Larger than A4/LT	200 sheets	250 sheets

Stapler Capacity (pages/set, 80 g/m², 20 lb paper):

	Punch mode	No punch mode
B5 sideways	80 sheets	100 sheets
A4 sideways		
LT sideways		
Other sizes	40 sheets	50 sheets

- Staple Position: 4 positions
 1-staple: 3 positions (Front, Rear, Rear-Oblique)
 2-staple: 1 position
- Staple Replenishment: Cartridge (5,000 staples)
- Power Source: 24 Vdc (from copier)
- Power Consumption: 120 W
- Weight: 60 kg
- Size (W x D x H): 800 mm x 730 mm x 980 mm

1.2 MECHANICAL COMPONENT LAYOUT

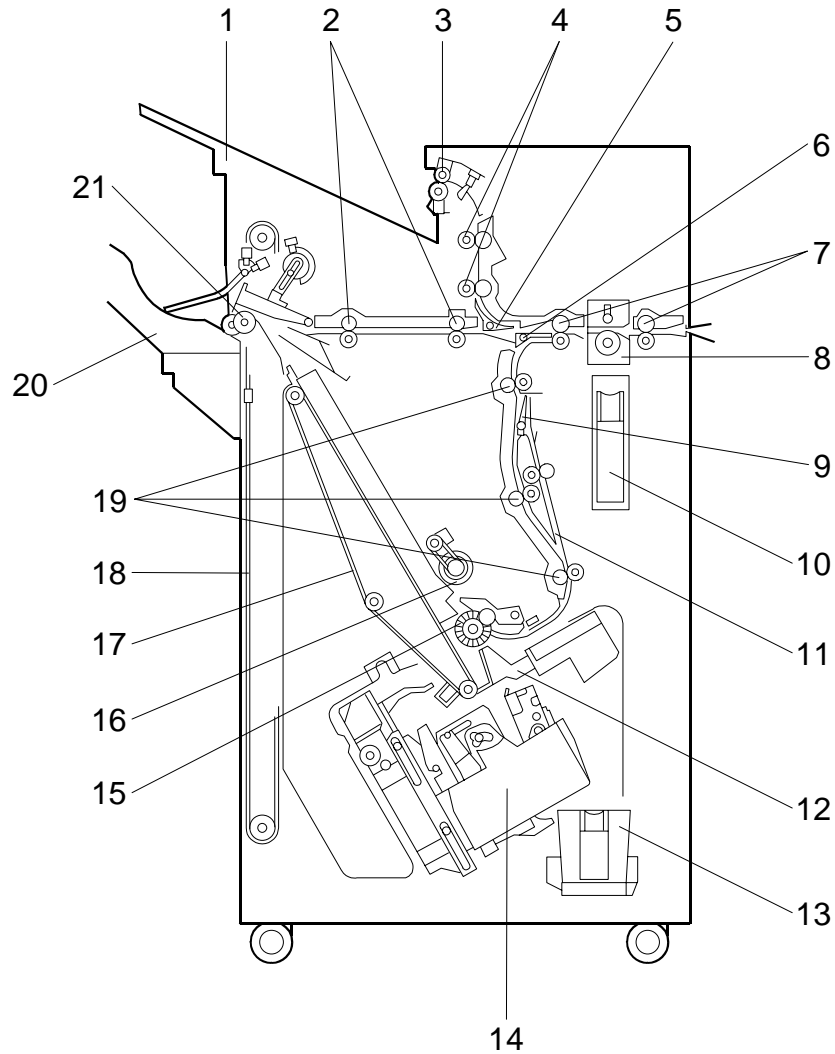

B302V500.WMF

- | | |
|-----------------------------|-----------------------------|
| 1. Upper Tray | 12. Stack Plate |
| 2. Middle Transport Rollers | 13. Staple Waste Hopper |
| 3. Upper Tray Exit Roller | 14. Stapler |
| 4. Upper Transport Rollers | 15. Alignment Brush Roller |
| 5. Tray Junction Gate | 16. Positioning Roller |
| 6. Stapler Junction Gate | 17. Stack Feed-out Belt |
| 7. Entrance Rollers | 18. Shift Tray Drive Belt |
| 8. Punch Unit | 19. Lower Transport Rollers |
| 9. Pre-stack Junction Gate | 20. Shift Tray |
| 10. Punch Waste Hopper | 21. Shift Tray Exit Roller |
| 11. Pre-stack Tray | |

1.3 ELECTRICAL COMPONENT DESCRIPTION

Symbol	Name	Function
Motors		
M1	Upper Transport	Drives the entrance rollers, the middle and upper transport rollers, and upper tray exit roller.
M2	Lower Transport	Drives the lower transport rollers, the alignment brush roller, and the positioning roller.
M3	Jogger	Moves the jogger fence.
M4	Stack Plate	Drives the stack plate.
M5	Stapler	Moves the staple unit from side to side.
M6	Stapler Rotation	Rotates the stapler 45 degrees.
M7	Staple Hammer	Drives the staple hammer.
M8	Stack Feed-out	Drives the stack feed-out belt.
M9	Exit Guide	Opens and closes the upper exit guide.
M10	Shift Tray Exit	Drives the exit roller for the shift tray.
M11	Shift	Moves the shift tray from side to side.
M12	Shift Tray Lift	Moves the shift tray up or down.
M13	Punch	Drives the punch shaft and roller.
Sensors		
S1	Entrance	Detects the copy paper entering the finisher and checks for misfeeds.
S2	Pre-stack Tray Paper	Determines when to turn off the pre-stack paper stopper solenoid.
S3	Stapler Tray Entrance	Detects the copy paper entering the stapler tray and checks for misfeeds.
S4	Jogger Fence HP	Detects the home position of the jogger fence.
S5	Stapler Tray Paper	Detects the copy paper in the stapler tray.
S6	Stack Plate HP	Detects the home position of the stack plate.
S7	Stapler HP	Detects the home position of the staple unit for side-to-side movement.
S8	Stapler Rotation HP	Detects the home position of the stapler unit for 45-degree rotation.
S9	Staple Hammer HP	Detects the home position of the staple hammer.
S10	Cartridge Set	Detects the staple cartridge in the stapler.
S11	Staple End	Detects the staples in the cartridge.
S12	Staple Waste Hopper	Detects when the staple waste hopper is full.
S13	Stack Feed-out Belt HP	Detects the home position of the stack feed-out belt.
S14	Exit Guide Open	Detects whether the guide plate is opened or not.
S15	Shift Tray Exit	Checks for misfeeds at the shift tray.
S16	Stack Height 1	Detects when the top of the copy paper stack in the shift tray is at the correct position.
S17	Stack Height 2	Detects when the top of the copy paper stack in the shift tray has become too high.
S18	Upper Tray Exit	Checks for misfeeds at the upper tray.

Symbol	Name	Function
S19	Upper Tray Paper Limit	Detects when the paper stack height in the upper tray is at its upper limit.
S20	Shift Tray Half-turn	Detects the return position for side-to-side movement of the shift tray.
S21	Shift Tray Lower Limit 1	Detects when the shift tray is nearly at its lower limit.
S22	Shift Tray Lower Limit 2	Detects when the shift tray is at its lower limit.
S23	Punch Waste Hopper	Detects when the punch waste hopper is full and detects when the punch tray is set.
S24	Punch HP	Detects the home position of the punch shaft and roller.
S25	Stapler Return	Detects the on timing of the stapler return solenoid.
Switches		
SW1	Front Door Safety	Cuts the dc power when the front door is opened.
SW2	Shift Tray Upper Limit	Cuts the power to the shift tray lift motor when the shift tray position is at its upper limit.
Solenoids		
SOL1	Stapler Junction Gate	Drives the stapler junction gate.
SOL2	Tray Junction Gate	Drives the tray junction gate.
SOL3	Pre-stack Junction Gate	Drives the pre-stack junction gate.
SOL4	Pre-stack Paper Stopper	Drives the pre-stack paper stopper.
SOL5	Positioning Roller	Moves the positioning roller against the stapling tray.
SOL6	Stapler Return	Returns the stapler to its guide from the user operation position.
PCBs		
PCB1	Main	Controls the finisher and communicates with the copier.
PCB2	Punch	Passes signals between the punch unit and the finisher main board.

1.4 DRIVE LAYOUT

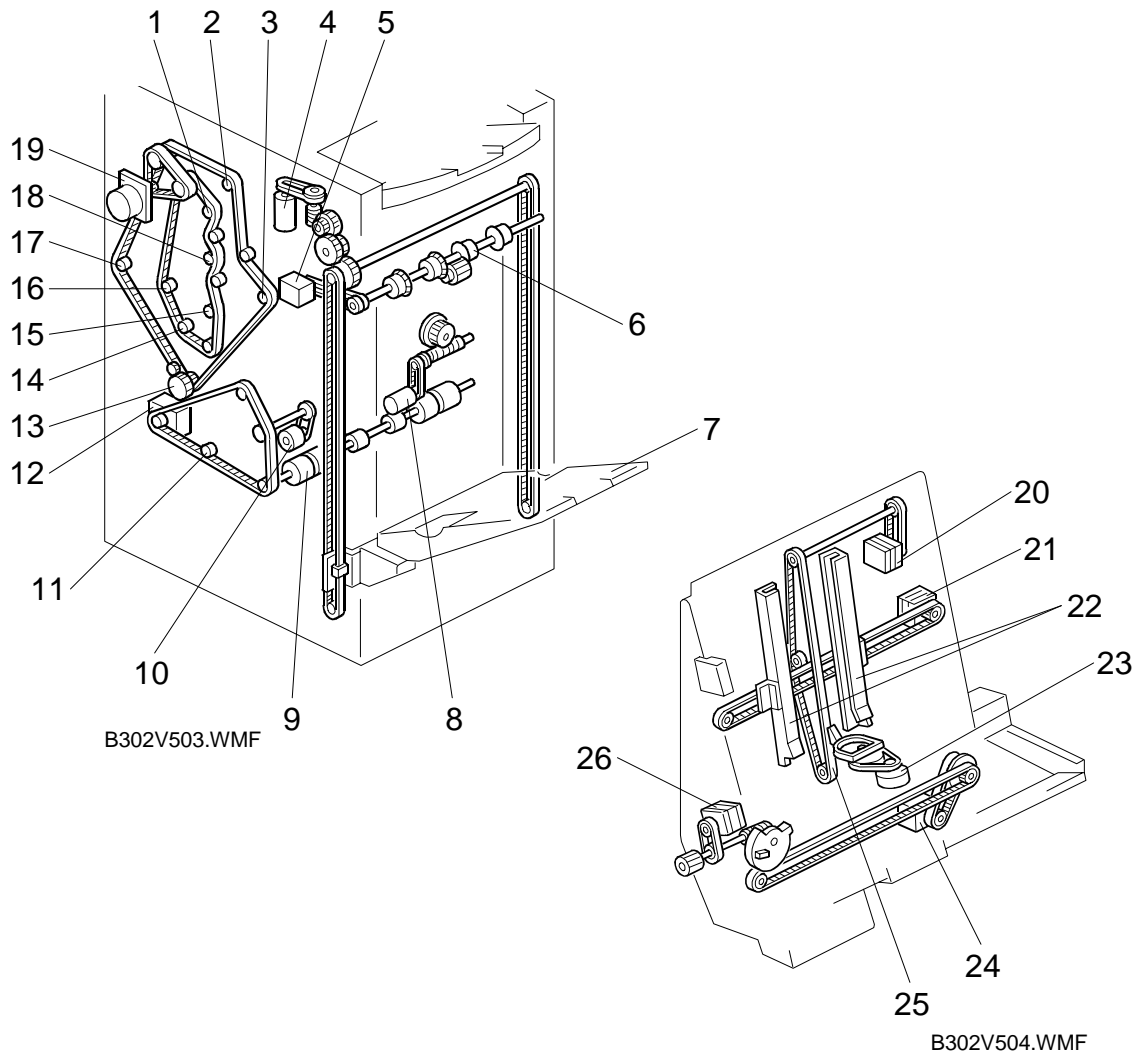

- | | |
|-------------------------------|------------------------------|
| 1. Upper Transport Roller 2 | 14. Lower Transport Roller 1 |
| 2. Upper Tray Exit Roller | 15. Transport Roller 1 |
| 3. Lower Transport Roller 2 | 16. Entrance Roller 2 |
| 4. Shift Tray Lift Motor | 17. Entrance Roller 1 |
| 5. Shift Tray Exit Motor | 18. Upper Transport Roller 1 |
| 6. Shift Tray Exit Roller | 19. Upper Transport Motor |
| 7. Shift Tray | 20. Stack Feed-out Motor |
| 8. Shift Motor | 21. Jogger Motor |
| 9. Staple Tray Exit Roller | 22. Jogger Fence |
| 10. Positioning Roller | 23. Stack Plate Motor |
| 11. Lower Transport Roller 3 | 24. Stapler Motor |
| 12. Lower Transport Motor | 25. Stack Feed-out Belt |
| 13. Lower Transport Rollers 2 | 26. Stapler Rotation Motor |

2. DETAILED DESCRIPTIONS

2.1 TRAY AND STAPLER JUNCTION GATE

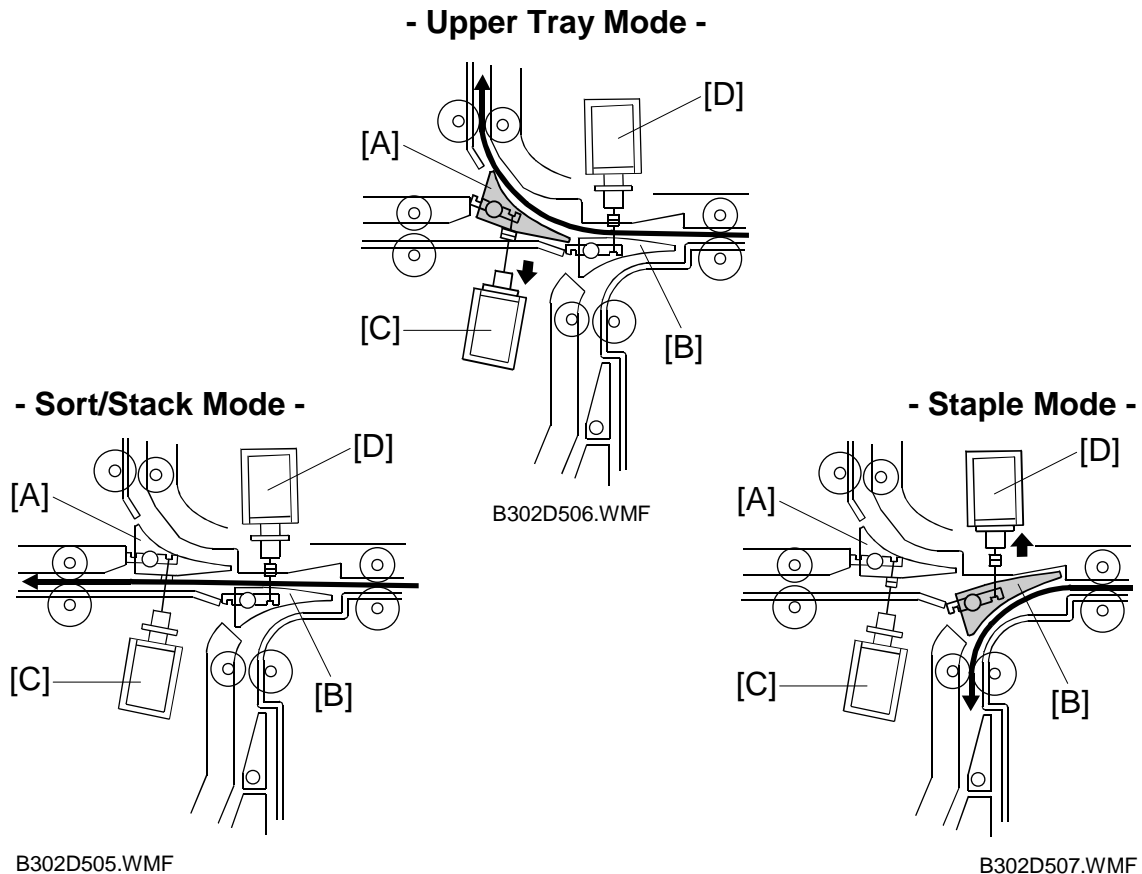

Depending on the finishing mode, the copies are directed up, straight through, or down by the combination of the tray junction gate [A] and stapler junction gate [B]. These gates are controlled by the tray junction gate solenoid [C] and stapler junction gate solenoid [D].

Upper Tray Mode

The stapler tray junction gate solenoid remains off and the tray junction gate solenoid turns on. The copies go up to the upper tray.

Sort/Stack Mode

The tray junction gate solenoid and the stapler junction gate solenoid remain off. The copies are sent to the shift tray directly.

Staple Mode

The stapler junction gate solenoid turns on. The copies go downwards to the jogger unit.

2.2 PAPER PRE-STACKING

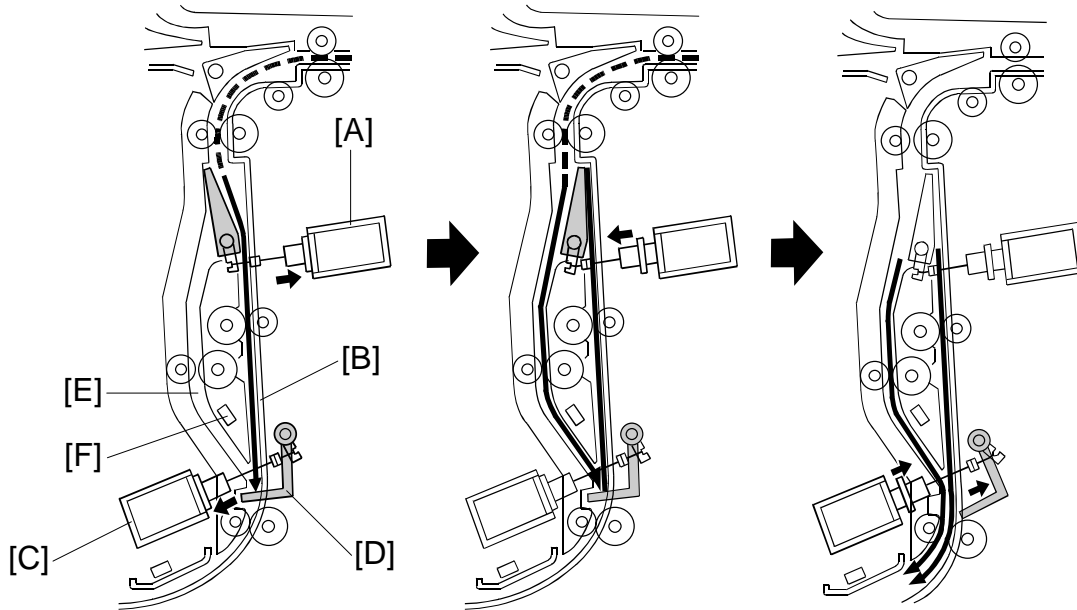

B302D000.WMF

This mechanism improves productivity in staple mode. It is only used when copying on A4, LT, or B5 (all sideways).

During stapling, the copier has to wait. This mechanism reduces the wait by holding the first two sheets of a job while the previous job is still being stapled. It only works during the second and subsequent sets of a multi-set copy job.

The pre-stack junction gate solenoid [A] turns on about 230 ms after the 1st sheet of paper turns on the entrance sensor, and this directs the sheet to the pre-stack tray [B]. (This sheet cannot be fed to the stapler yet, because the first set is still being stapled.) The pre-stack paper stopper solenoid [C] turns on about 680 ms after the 1st sheet turns on the entrance sensor. The pre-stack paper stopper [D] then stops the paper.

The pre-stack junction gate solenoid turns off 450 ms after the trailing edge of the 1st sheet passes through the entrance sensor, and the 2nd sheet is sent to the paper guide [E]. The pre-stack paper stopper is released about 50 ms after the 2nd sheet turns on the pre-stack stopper sensor [F], and the two sheets of copy paper are sent to the stapler tray. All sheets after the 2nd sheet go to the stapler tray via the paper guide [E].

2.3 JOGGER UNIT PAPER POSITIONING

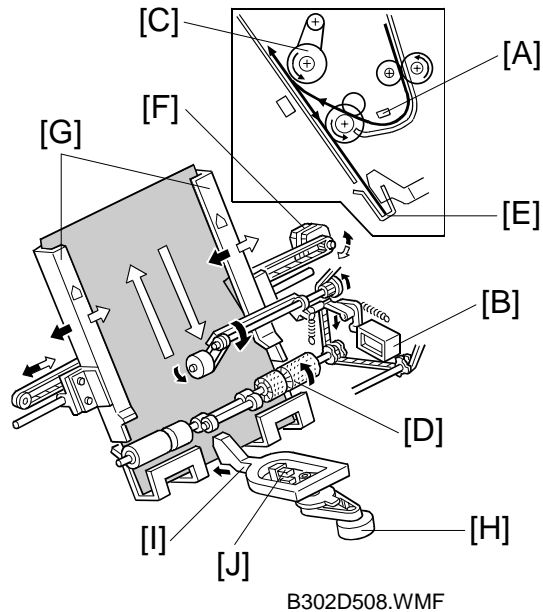

In staple mode, each sheet of copy paper is vertically and horizontally aligned when it arrives in the jogger unit.

Vertical Paper Alignment

Approximately 60 ms after the trailing edge of the copy passes the staple tray entrance sensor [A], the positioning roller solenoid [B] is energized to push the positioning roller [C] into contact with the paper. The positioning roller and alignment brush roller [D] rotate to push the paper back and align the trailing edge of the paper against the stack stopper [E].

Horizontal Paper Alignment

When the print key is pressed, the jogger motor [F] turns on and the jogger fences [G] move to the waiting position, which is approximately 7 mm wider on both sides than the selected paper.

When the trailing edge of the paper passes the staple unit entrance sensor, the jogger motor turns on for approximately 32 ms (4.7 mm) to move the jogger fences approximately 5 mm towards the paper. After a short time, the jogger motor turns on again approximately 18 ms (3.0 mm) for the horizontal paper alignment then goes back to the waiting position.

Paper Stack Correction

After the paper is aligned in the stapler tray, the stack plate motor turns [H] on for short time to correct the paper stack and the stack plate [I] push the paper against the staple tray.

When the next copy paper turns on the stapler tray entrance sensor, the stack plate motor turns on again to return to its home position. The home position is detected by stack plate HP sensor [J].

2.4 STAPLER UNIT MOVEMENT

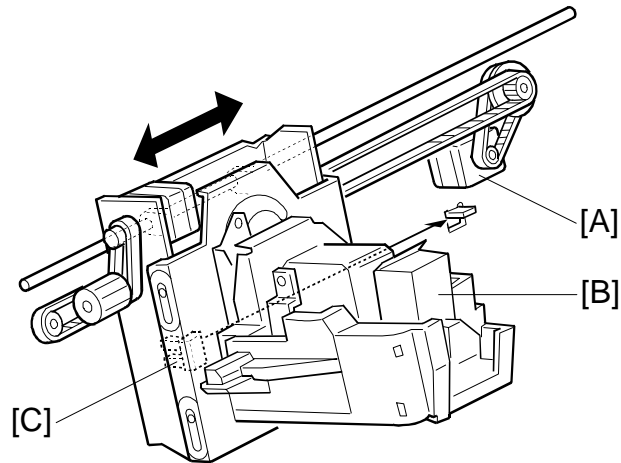

B302D513.WMF

Side-to-Side

The stapler motor [A] moves the stapler [B] from side to side. After the start key is pressed, the stapler moves from its home position to the stapling position.

If two-staple-position mode is selected, the stapler moves to the front stapling position first, then moves to the rear stapling position. However, for the next copy set, it staples in the reverse order (at the rear side first then at the front side).

After the job is completed, the stapler moves back to its home position. This is detected by the stapler HP sensor [C].

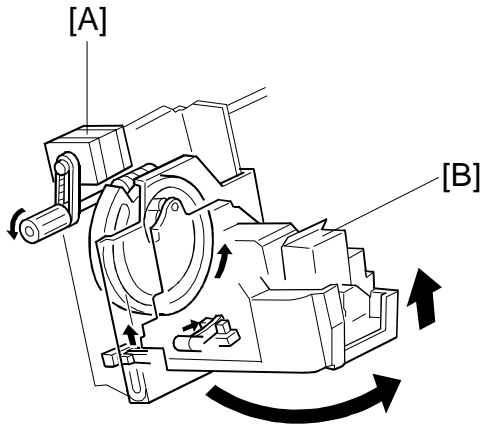

B302D514.WMF

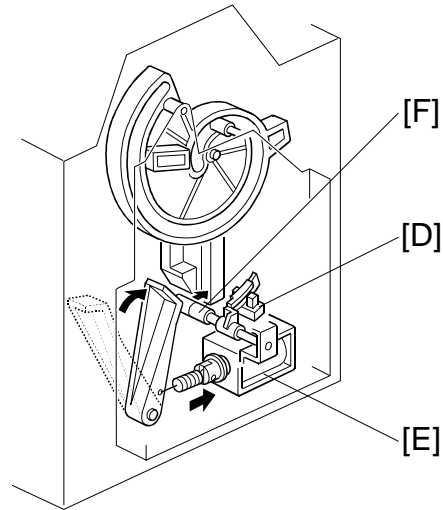

B302D523.WMF

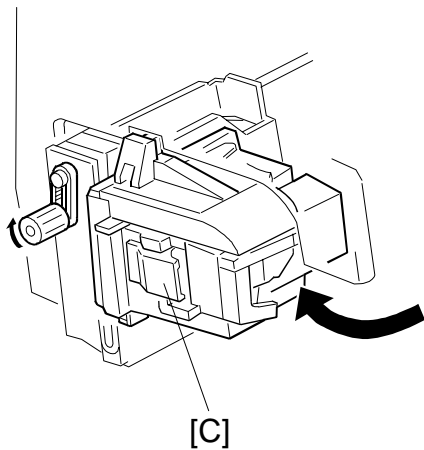

B302D515.WMF

Rotation (1)

In the oblique staple position mode, the stapler rotation motor [A] rotates the stapler units [B] 45° to counterclockwise after it moves to the stapling position.

Rotation (2)

When the staple end condition arises, the stapler motor moves the stapler to the front and the stapler rotation motor rotates the stapler unit to clockwise to remove the staple cartridge [C]. This allows the user to add new staples.

Once the staples have been installed, and the front door closed, the stapler unit returns to its home position. As the stapler unit is returning to the home position, the stapler return sensor [D] is activated, the return solenoid [E] turns on and it assists the guide roller [F] to return to its guide (this guide directs the stapler during rotation).

Options

2.5 STAPLER

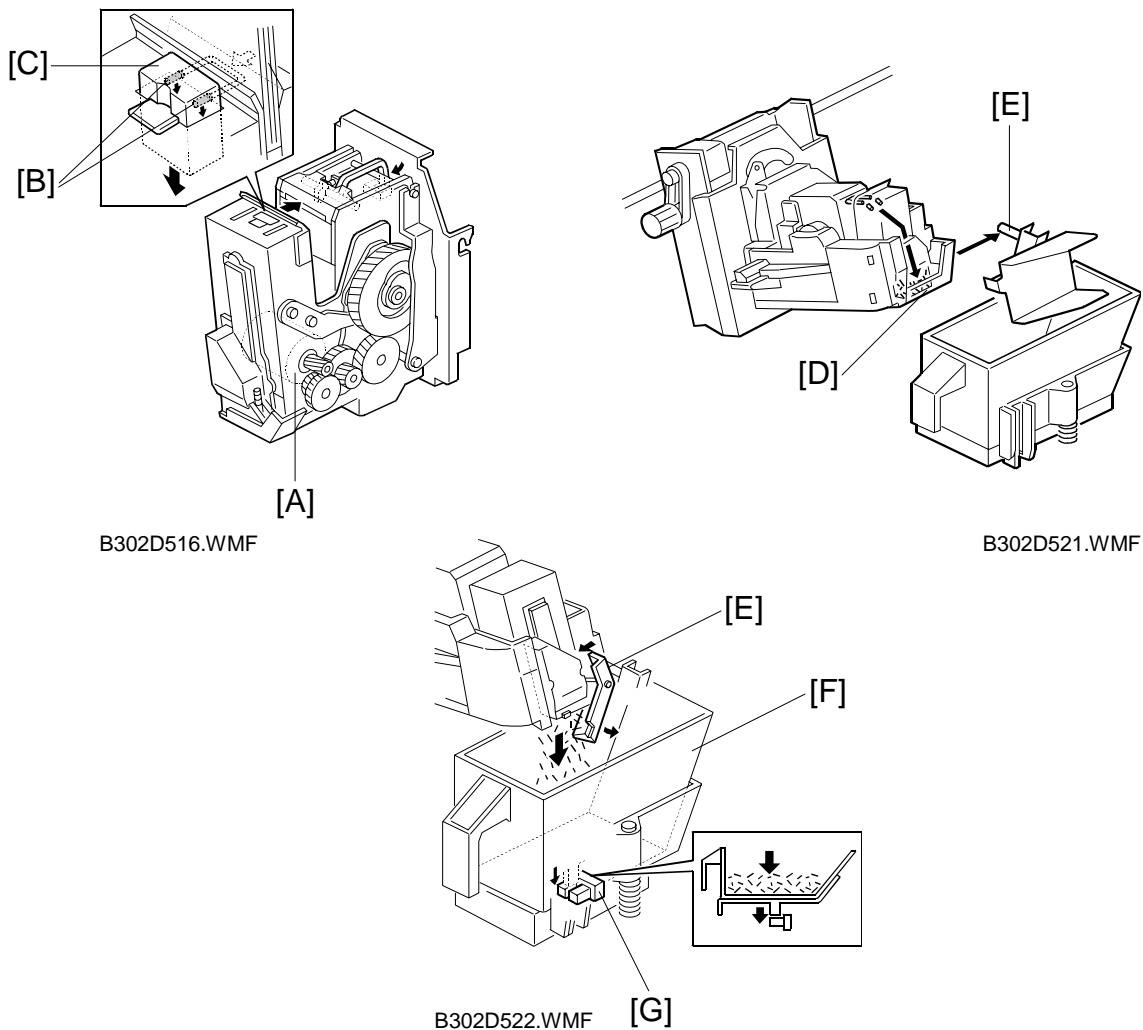

When the aligned copies are brought to the stapling position by the positioning roller and jogger fences, the staple hammer motor [A] starts stapling.

During stapling, the stapler trims off the excess length [B] of the staples by lowering the cutter [C]. This excess length depends on the number of copies in the set; there will be very little for a stack containing 100 sheets. The staple waste drops into the tray [D] in the stapler. When the stapler unit returns to its home position, the tray hits the shaft [E] and the tray opens. The staple waste drops into the staple waste hopper [F]. When the staple waste hopper is full, the actuator on its base activates the staple waste hopper sensor [G]. An SC is displayed.

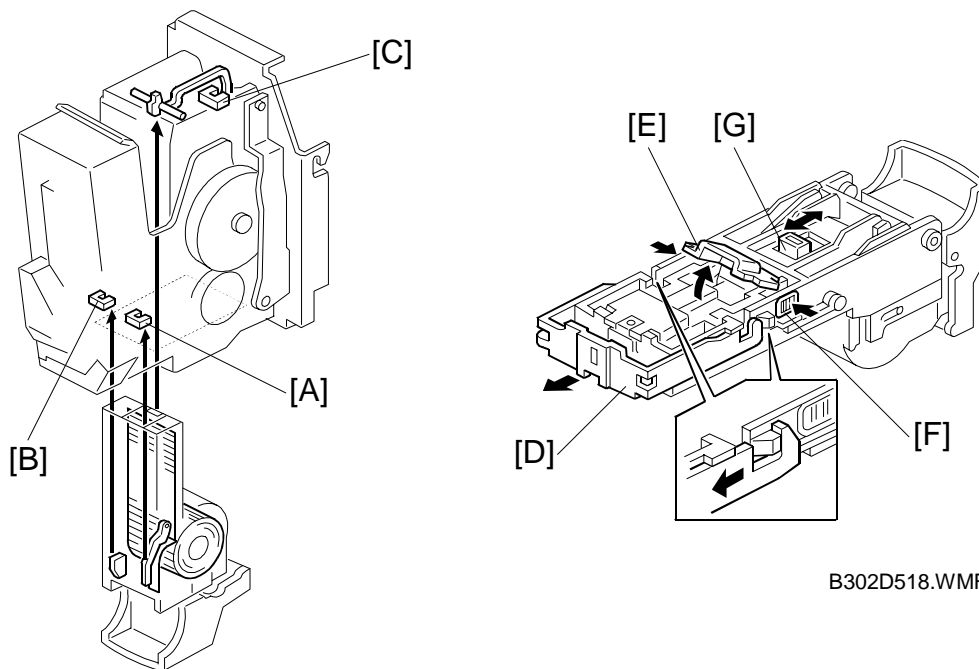

B302D517.WMF

B302D518.WMF

The stapler has a staple end sensor [A], cartridge set sensor [B] and staple hammer HP sensor [C].

When a staple end or no cartridge condition is detected, a message is displayed advising the operator to install a staple cartridge. If this condition is detected during a copy job, the indication will appear, and the copy job will stop.

The staple cartridge has a clinch area [D], in which jammed staples are left. Operators can remove the jammed staples from this area.

When the operator lifts the release lever [E], the clinch area is released from the cartridge by pushing the holders [F]. The jammed staples can be removed.

The staple sheet can be feed manually by sliding the knob [G].

2.6 FEED-OUT

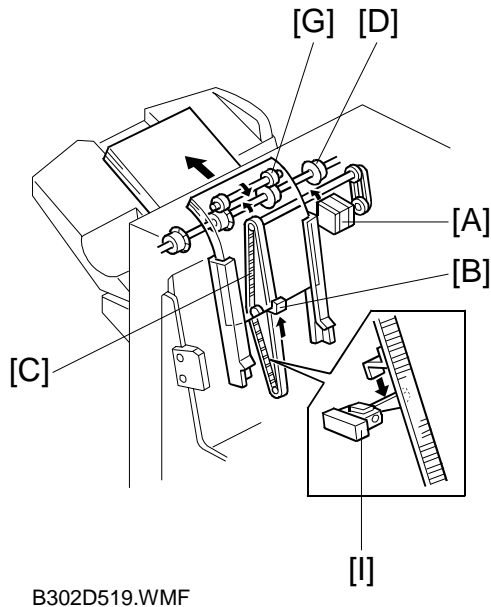

B302D519.WMF

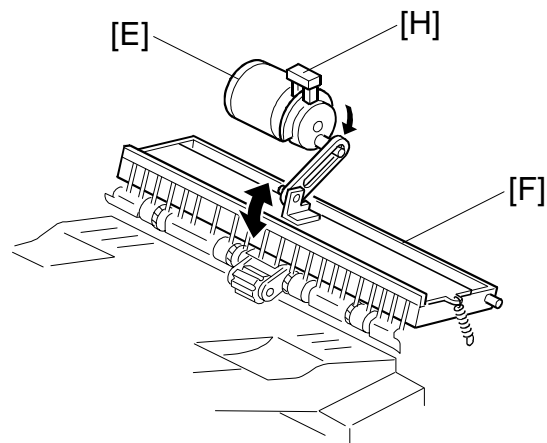

B302D512.WMF

After the copies have been stapled, the stack feed-out motor [A] starts. The pawl [B] on the stack feed-out belt [C] transports the set of stapled copies up and feeds it to the shift tray exit roller [D]. When stapling starts, the exit guide motor [E] opens the upper exit guide [F], which includes the upper shift tray exit roller [G], in order to feed out the leading edge of the copy set smoothly. The exit guide motor turns on again a certain time after stapling is complete, and the upper exit guide plate is lowered. Then the shift tray exit roller takes over the stack feed-out.

The on-off timing of the exit guide motor is detected by the exit guide open sensor [H].

The stack-feed-out motor turns off when the pawl actuates the stack feed-out belt home position sensor [I].

2.7 SHIFT TRAY UP/DOWN MOVEMENT

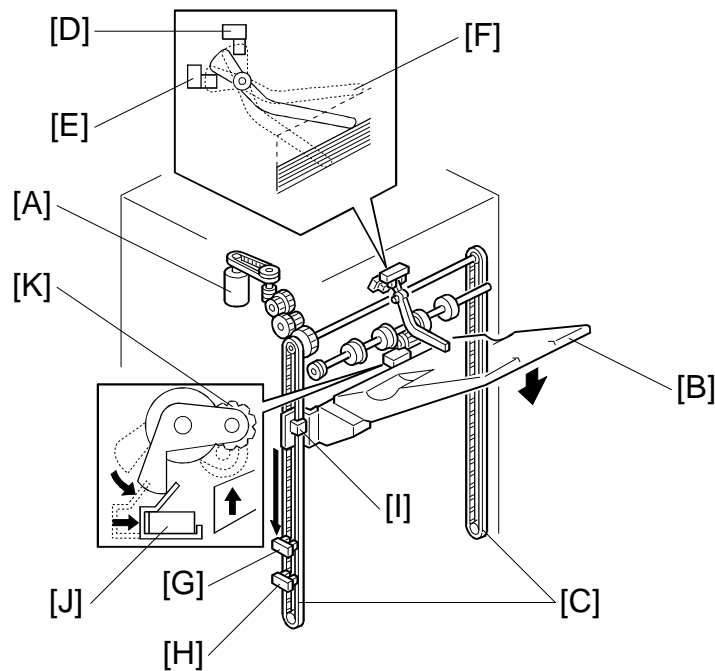

B302D010.WMF

The shift tray lift motor [A] controls the vertical position of the shift tray [B] through gears and timing belts [C]. When the main switch is turned on, the tray is initialized at the upper position. The tray is moved up until stack height sensor 1 [D] is de-actuated.

In sort/stack mode, if stack height sensor 2 [E] is actuated for 2 seconds, the shift tray lift motor lowers the shift tray for 20 ms.

In staple mode, when the pawl on the stack feed-out belt reaches the upper position of the staple unit, the shift tray lift motor lowers the shift tray for 400 ms and stops for 200 ms. Then, it lifts the shift tray until stack height sensor 1 is de-actuated by the feeler [F]. This means the tray lowers earlier in staple mode, to prevent the next copy suddenly exceeding the space currently available on the tray.

For both modes, the shift tray will rise until stack height sensor 1 is de-actuated when the user takes the stack of paper from the shift tray.

This machine has two shift tray lower limit sensors 1 [G], 2 [H]. Shift tray lower limit sensor 1 detects the near lower limit and sensor 2 detects the lower limit. When the actuator [I] enters sensor 1, a message will be displayed and copying will continue. When the actuator enters sensor 2, a message will be displayed and copying will stop.

The shift tray upper limit switch [J] prevents the drive gear from being damaged if stack height sensor 1 fails. When the shift tray pushes up the shift tray positioning roller [K], the switch will cut the power to the shift tray lift motor.

2.8 SHIFT TRAY SIDE-TO-SIDE MOVEMENT

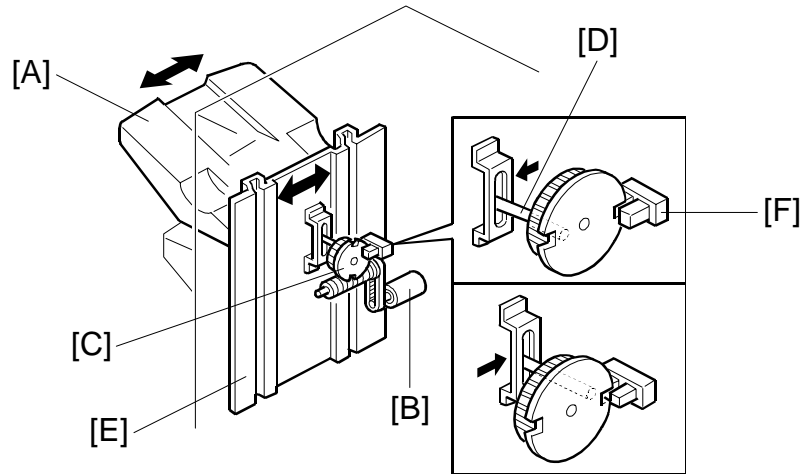

B302D520.WMF

In sort/stack mode, the shift tray [A] moves from side to side to separate the sets of copies.

The horizontal position of the shift tray is controlled by the shift motor [B] and shift gear disk [C]. After one set of copies is made and delivered to the shift tray, the shift motor turns on, driving the shift gear disk and the shaft [D]. The end fence [E] is positioned by the shaft, creating the side-to-side movement.

When the shift gear disk has rotated 180 degrees (when the shift tray is fully shifted across), the cut-out in the shift gear disk turns on the shift tray half-turn sensor [F] and the shift motor stops. The next set of copies is then delivered. The motor turns on, repeating the same process and moving the tray back to the previous position.

2.9 PUNCH UNIT DRIVE

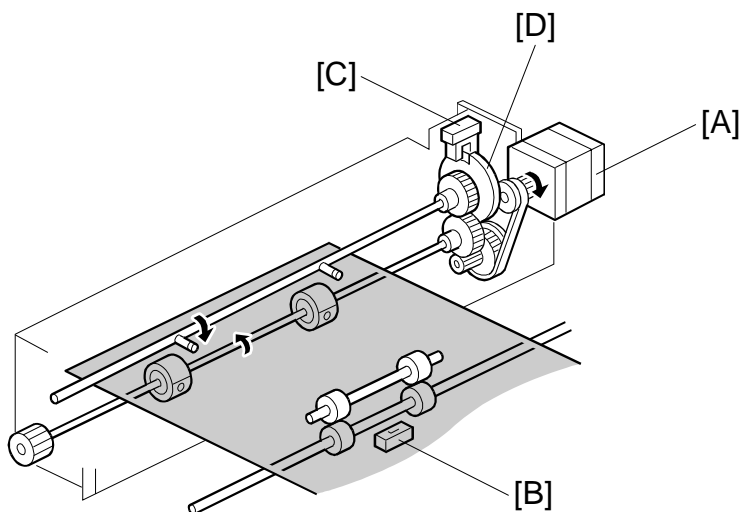

B302D001.WMF

The punch unit makes 2 or 3 holes (depending on the type of punch unit) at the trailing edge of the paper.

The punch unit is driven by the punch motor [A]. The punch motor turns on 78 ms after the trailing edge of the paper passes through the entrance sensor [B], and makes the punch holes.

The home position is detected by the punch HP sensor [C]. When the cut-out in the punch shaft gear disk [D] enters the punch HP sensor, the punch motor stops.

The punch position is adjusted as follows:

- Right to left: SP mode
- Front to rear: Spacers

2.10 PUNCH WASTE COLLECTION

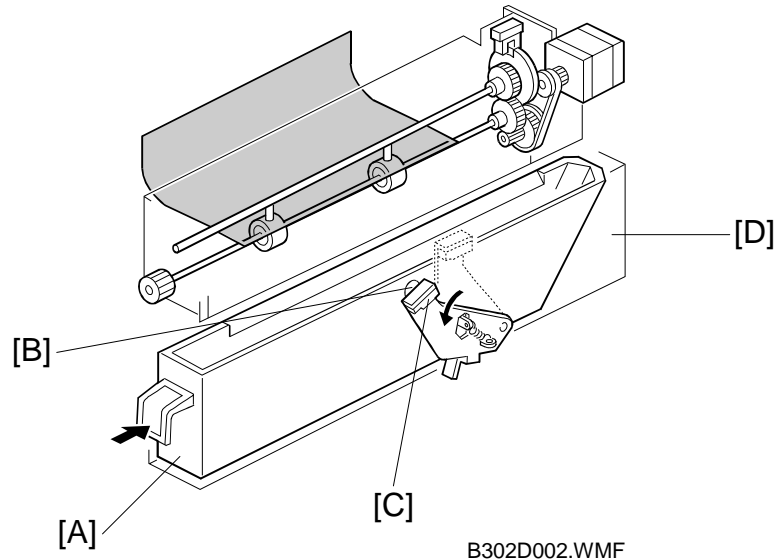

The punch waste is collected in the punch waste hopper [A], which is under the punch unit.



When the punch waste covers the hole [B] in the hopper, the punch waste hopper sensor [C] turns on and a message will be displayed after the copy job finishes.

The punch waste hopper sensor also works as the hopper set sensor. If the punch waste hopper is not set, the sensor stays away from the hole in the hopper holder [D] and a message is displayed. This message is the same as for the hopper full condition.

2.11 JAM CONDITIONS

1. The entrance sensor does not turn on when the copier has fed paper 426 mm after the copier exit sensor turned off.
2. The entrance sensor does not turn off when the upper transport motor has fed paper 1.5 times the paper's length after it turned on.
3. The upper tray exit sensor does not turn on when the upper transport motor has fed paper 574 mm after the entrance sensor turned on.
4. The upper tray exit sensor does not turn off when the upper transport motor has fed paper 1.5 times the paper's length after it turned on.
5. In sort/stack mode, the shift tray exit sensor does not turn on when the upper transport motor has fed paper 783 mm after the entrance sensor turned on.
6. In sort/stack mode, the shift tray exit sensor does not turn off when the upper transport motor has fed paper 1.5 times the paper's length after it turned on.
7. In staple mode, the stapler tray entrance sensor does not turn on when the upper and lower transport motor have fed paper 835 mm after the entrance sensor turned on.
8. In staple mode, the stapler tray entrance sensor does not turn off when the upper transport motor has fed paper 1.5 times the paper's length after it turned on.
9. In staple mode, the stapler tray paper sensor does not turn off within 250 pulses of the stack feed-out motor after it started.
10. In staple mode, the shift tray exit sensor does not turn off within 1,260 ms after the stack feed-out motor started.

3. SERVICE TABLES

3.1 DIP SWITCHES

DPS100				Description
1	2	3	4	
0	0	0	0	Default
1	0	0	0	Free run: A4 sideways, staple mode
0	1	0	0	Free run: staple and tray shift

NOTE: Do not use any other settings.

3.2 TEST POINTS

No.	Label	Monitored Signal
TP100	(5V)	+5 V
TP101	(GND)	Ground
TP102	(RXD)	RXD
TP103	(TXD)	TXD

3.3 FUSES

No.	Function
FU100	Protects 24 V.

4. REPLACEMENT AND ADJUSTMENT

4.1 COVER REPLACEMENT

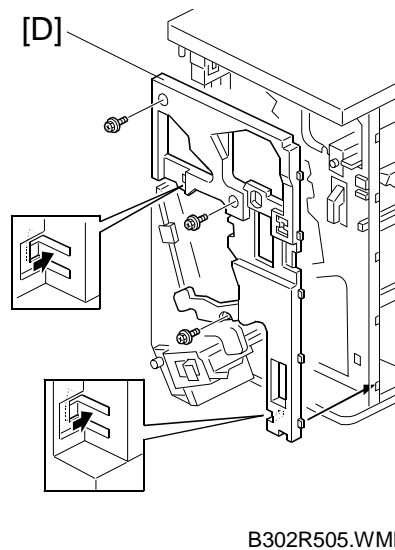
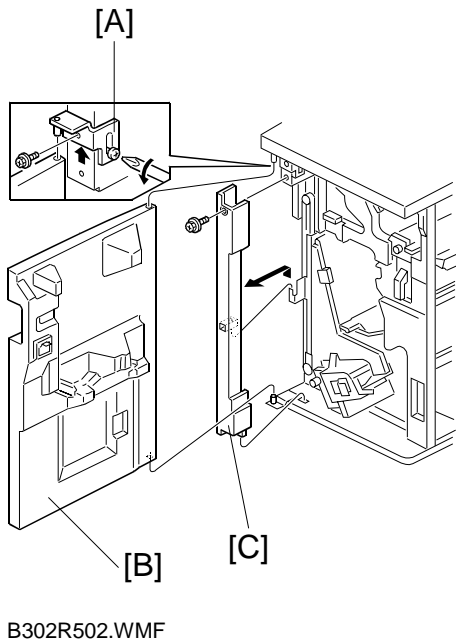

Front Door

1. Remove one screw and loosen the other screw of the upper hinge for the front door [A].
2. Remove the front door [B].

Left Inner Cover

1. Remove the front door.
2. Remove the left inner cover [C] (1 screw).

Inner Cover

1. Remove the three screws and unhook the pawls.
2. Remove the inner cover [D].

Options

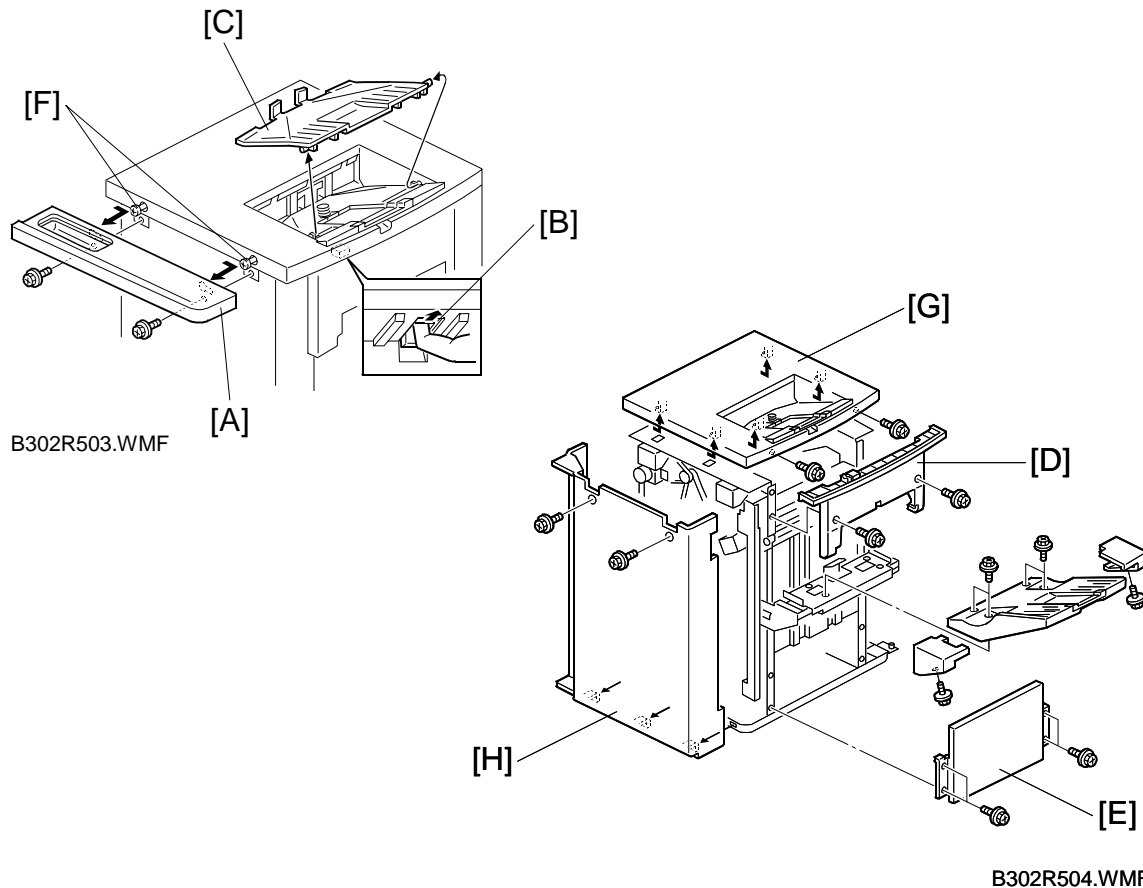
**Table**

1. Slide the table [A] to the right and remove it (2 screws).

Upper Tray

1. Click the release lever [B].
2. Remove the upper tray [C].

Left Upper Cover

1. Remove the left upper cover [D].

Left Lower Cover

1. Remove the left lower cover [E].

Upper Cover

1. Remove the table.
2. Remove two stepped screws [F].
3. Remove the left upper cover.
4. Slide across the right cover [G] and remove it (2 screws).

Rear Cover

1. Remove the rear cover [H] (2 screws).

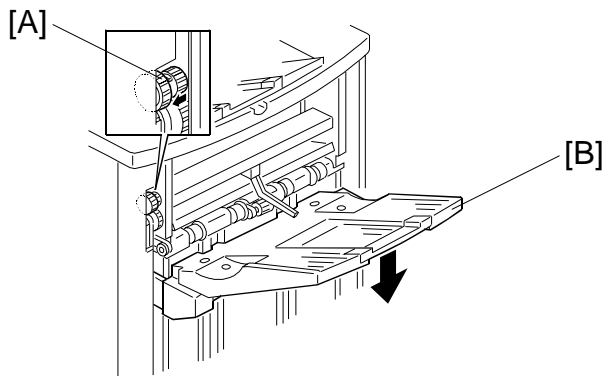

B302R501.WMF

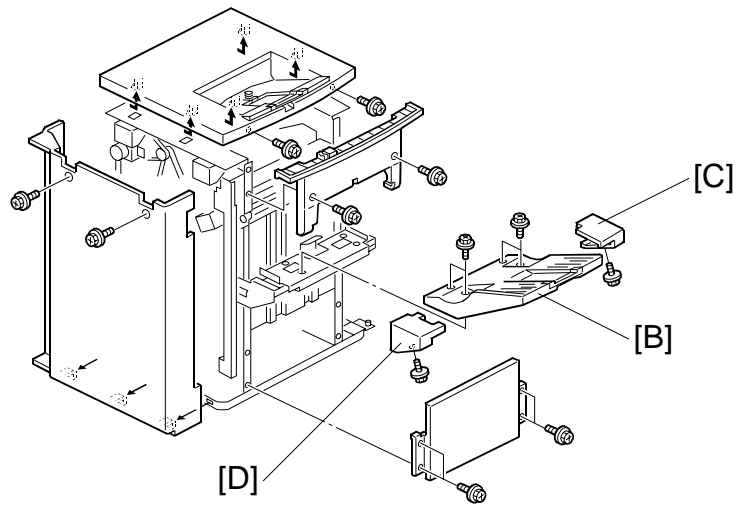

B302R504.WMF

Shift Tray

1. Remove the left upper cover.
2. Rotate the shift tray lift gear [A] manually to lower the shift tray [B]
3. Remove the shift tray (4 screws).

Front Shift Tray Cover

1. Remove the front shift tray cover [C] (1 screw).

Rear Shift Tray Cover

1. Remove the rear shift tray cover [D] (1 screw).

Options

4.2 POSITIONING ROLLER REPLACEMENT

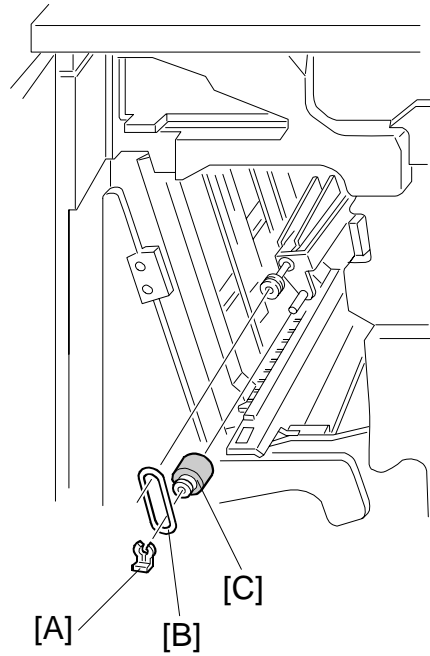

B302R506.WMF

1. Open the front door.
2. Remove the snap ring [A].
3. Release the rubber belt [B].
4. Replace the positioning roller [C].

4.3 ALIGNMENT BRUSH ROLLER REPLACEMENT

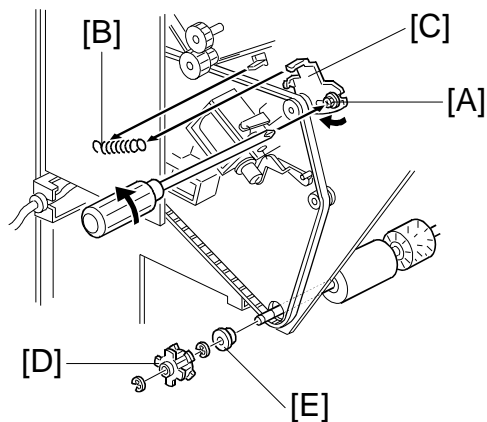

B302R507.WMF

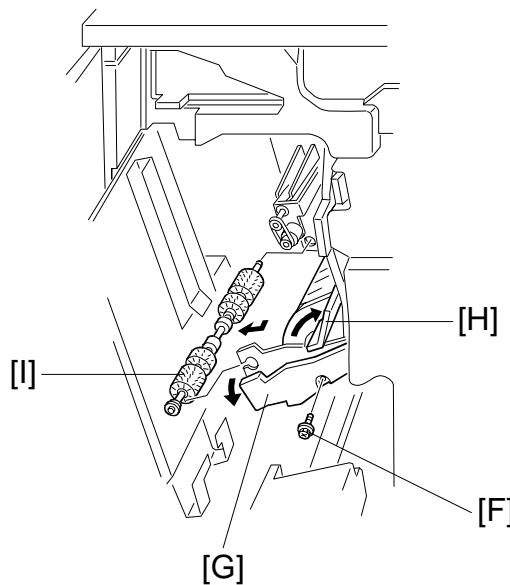

B302R508.WMF

1. Open the front door and pull out the staple unit.
2. Remove the rear cover.
3. Remove the screw [A] and a tension spring [B] for the tension bracket [C], and release the tension of the timing belt.
4. Remove the pulley [D] and ball bearing [E] (1 E-ring each).
5. Remove screw [F] of the inner cover [G].
6. Open the guide [H] and a part of the inner cover, and remove the alignment brush roller assembly [I] (1 E-ring).
7. Replace the alignment brush roller (1 E-ring, 1 ball bearing).

Options

4.4 SENSOR REPLACEMENT

4.4.1 STACK HEIGHT 1, 2 AND EXIT GUIDE OPEN SENSOR

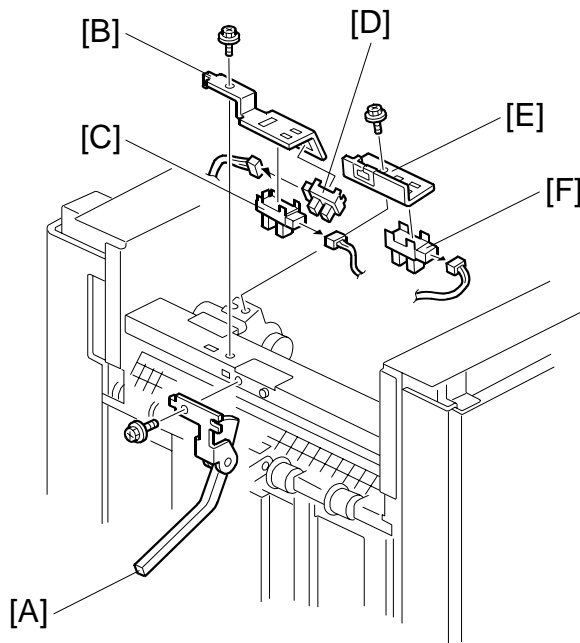

B302R509.WMF

1. Remove the upper cover.

Stack Height Sensors 1 and 2

2. Remove the sensor feeler [A] (1 screw).
3. Remove the sensor bracket [B] (1 screw).
4. Replace the stack height sensor 1 [C] or 2 [D] (1 connector each).

Exit Guide Open Sensor

2. Remove the sensor bracket [E] (1 screw).
3. Replace the exit guide open sensor [F] (1 connector).

4.4.2 UPPER TRAY PAPER LIMIT AND EXIT SENSOR

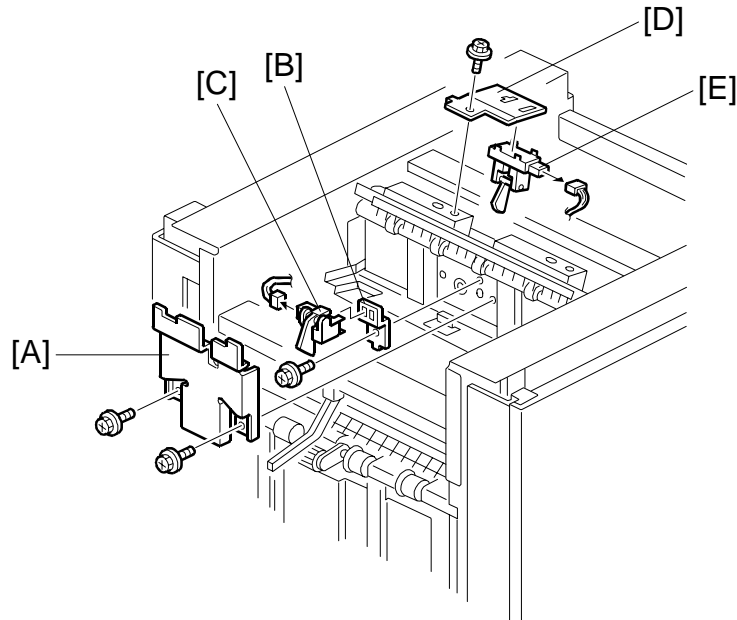

B302R510.WMF

1. Remove the upper cover.

Upper Tray Paper Limit Sensor

2. Remove the sensor cover [A] (2 screws).
3. Remove the sensor bracket [B] (1 screw).
4. Replace the upper tray paper limit sensor [C] (1 connector).

Upper Tray Exit Sensor

2. Remove the sensor bracket [D] (1 screw).
3. Replace the upper tray exit sensor [E] (1 connector).

Options

4.4.3 SHIFT TRAY EXIT SENSOR

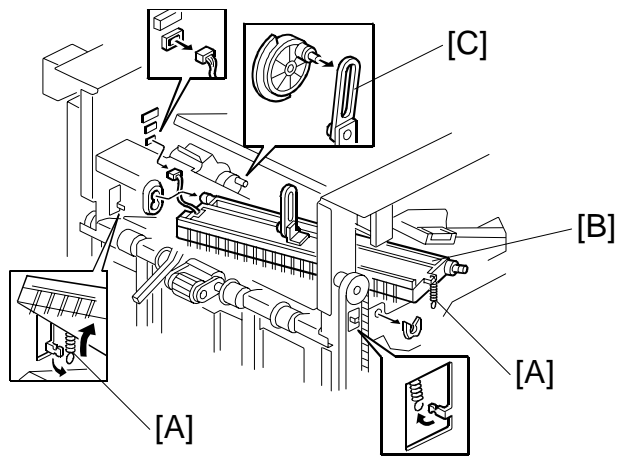

B302R511.WMF

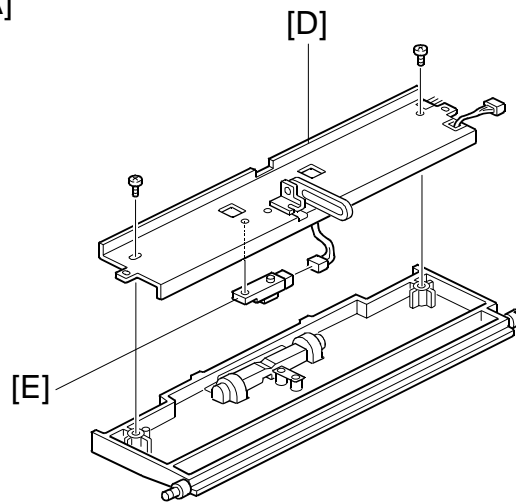

B302R512.WMF

1. Remove the upper cover.
2. Open the front door.
3. Remove the inner cover.
4. Release two springs [A] of the upper exit guide [B].
5. Release the link [C] from the cam and remove the upper exit guide (1 plastic clip, 1 connector).
6. Remove the guide stay [D] (2 screws).
7. Replace the shift tray exit sensor [E] (1 screw, 1 connector).

4.4.4 ENTRANCE AND STAPLER TRAY ENTRANCE SENSORS

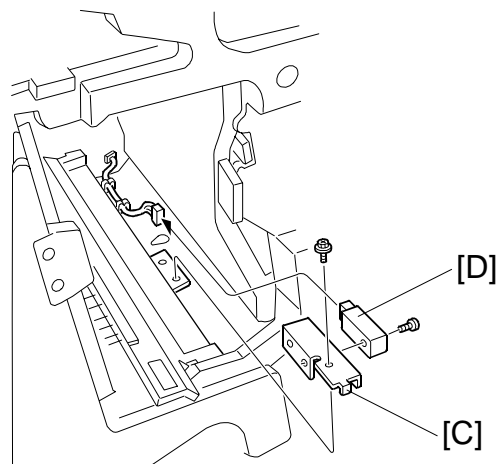
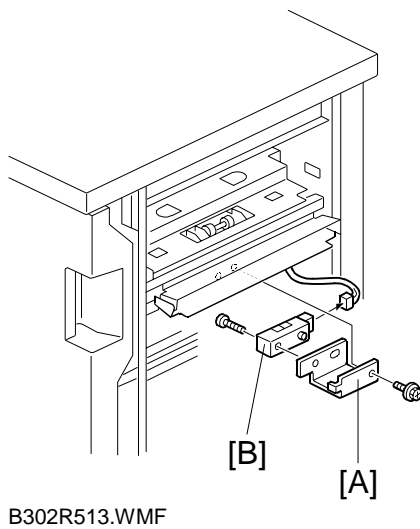

Entrance Sensor

1. Remove the finisher from the copier.
2. Remove the sensor bracket [A] (1 screw).
3. Replace the entrance sensor [B] (1 screw, 1 connector).

Stapler Tray Entrance Sensor

1. Open the front door.
2. Remove the sensor bracket [C] (1 screw).
3. Replace the stapler tray entrance sensor [D] (1 screw, 1 connector).

4.4.5 PRE-STACK STOPPER SENSOR

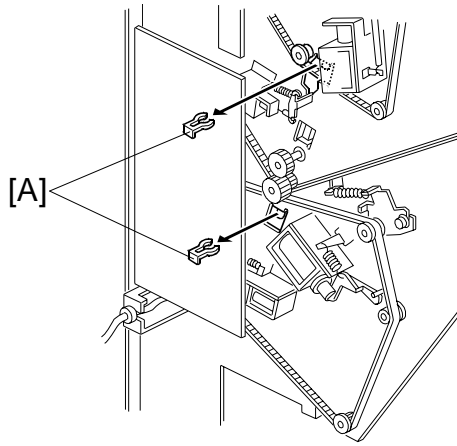

B302R515.WMF

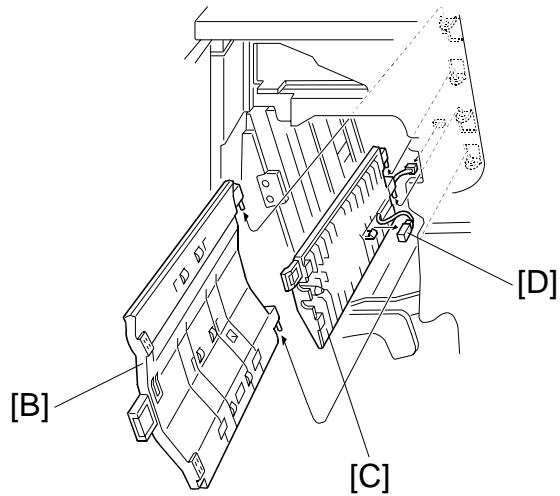

B302R516.WMF

1. Remove the rear cover.
2. Remove two plastic clips from the guide [A].
3. Open the front door.
4. Remove the left vertical transport guide [B].
5. Remove the middle vertical transport guide [C] (1 connector).
6. Replace the pre-stack paper sensor [D] (1 connector).

4.4.6 STAPLE WASTE HOPPER SENSOR

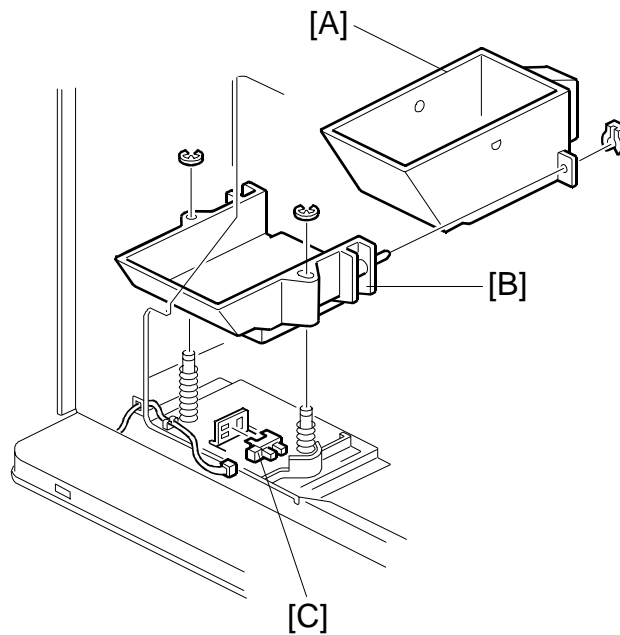

B302R517.WMF

1. Open the front door and pull out the stapler unit.
2. Remove the staple waste hopper [A] (1 plastic clip).
3. Remove the hopper holder [B] (2 E-rings).
4. Replace the staple waste hopper sensor [C] (1 connector).

4.4.7 STAPLER ROTATION HP AND STAPLER RETURN SENSORS

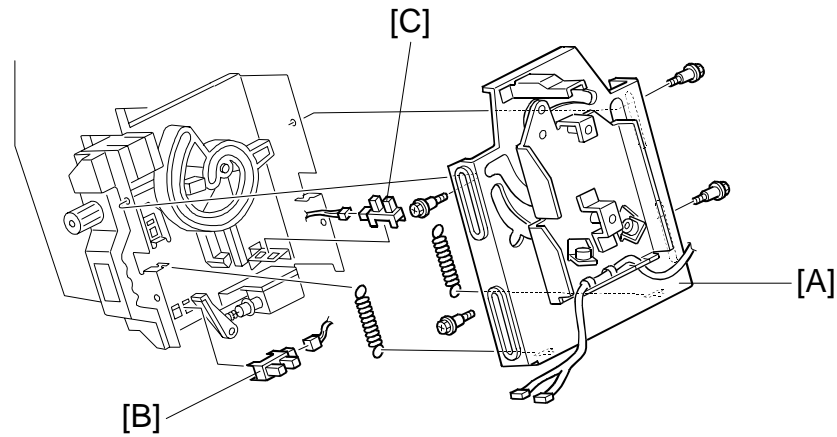

B302R519.WMF

1. Remove the stapler unit.
2. Remove the stapler bracket [A] (4 screws, 2 springs).

Stapler Rotation HP Sensor

3. Replace the stapler rotation HP sensor [B] (1 connector).

Stapler Return Sensor

3. Replace the stapler return sensor [C] (1 connector).

4.5 STAPLER REMOVAL

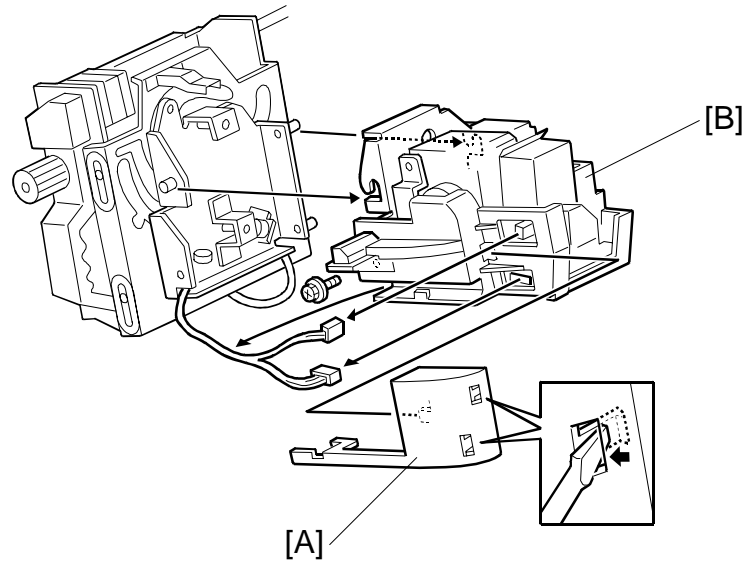

B302R518.WMF

1. Open the front door and pull out the staple tray.
2. Remove the stapler unit harness cover [A].
3. Remove the stapler [B] (1 screw, 2 connectors).

4.6 PUNCH POSITION ADJUSTMENT

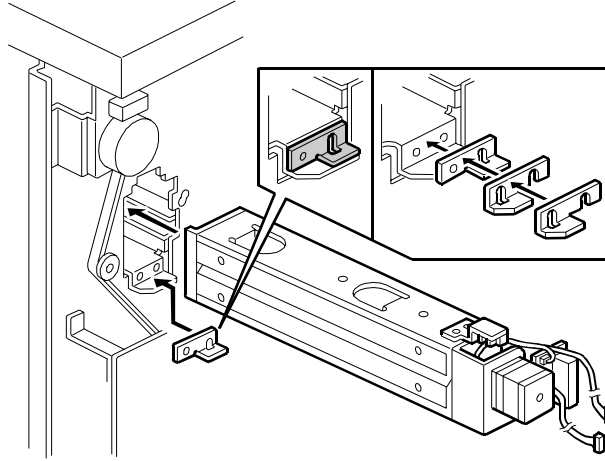

B302R520.WMF

Right to Left

This position is adjusted by SP modes.

Front to Rear

The optional punch units have the following 3 spacers as accessories.

1 mm thickness: 2 pcs

2 mm thickness: 1 pc

The punch position can be adjusted by up to 4 mm by combinations of the 3 spacers.

ELECTRICAL COMPONENT LAYOUT (FINISHER: B302)

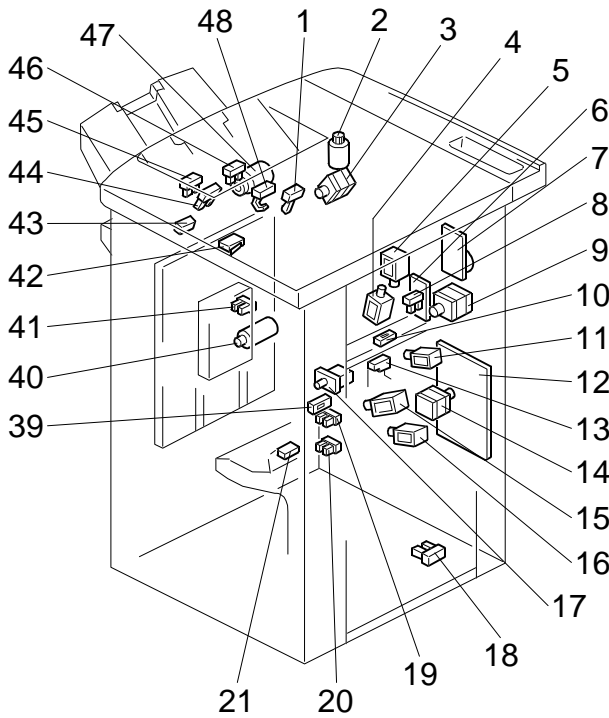

B302S501.WMF

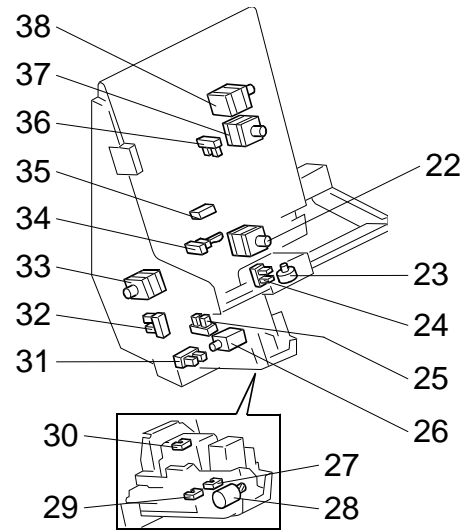

B302S502.WMF

Symbol	Index No.	Description	P to P
Motors			
M1	7	Upper Transport	A6
M2	14	Lower Transport	C6
M3	37	Jogger	F6
M4	23	Stack Plate	G6
M5	22	Stapler	G6
M6	33	Stapler Rotation	I6
M7	28	Staple Hammer	I6
M8	38	Stack Feed-out	F6
M9	47	Exit Guide	C6
M10	3	Shift Tray Exit	B6
M11	40	Shift	D6
M12	2	Shift Tray Lift	C6
M13	9	Punch	J2
Sensors			
S1	10	Entrance	B2
S2	39	Pre-stack	E2
S3	21	Stapler Tray Entrance	F2
S4	36	Jogger Fence HP	F2
S5	35	Stapler Tray Paper	F2
S6	24	Stack Plate HP	G2
S7	32	Stapler HP	G2
S8	31	Stapler Rotation HP	G2
S9	30	Staple Hammer HP	J2
S10	29	Cartridge Set	J2
S11	27	Staple End	J2
S12	18	Staple Waste Hopper	I2
S13	34	Stack Feed-out Belt HP	F2
S14	46	Exit Guide Open	C2

Symbol	Index No.	Description	P to P
S15	43	Shift Tray Exit	C2
S16	45	Stack Height 1	D2
S17	44	Stack Height 2	D2
S18	1	Upper Tray Exit	C2
S19	48	Upper Tray Paper Limit	C2
S20	41	Shift Tray Half-turn	D2
S21	19	Shift Tray Lower Limit 1	E2
S22	20	Shift Tray Lower Limit 2	E2
S23	13	Punch Waste Hopper	J2
S24	8	Punch HP	I2
S25	25	Stapler Return	I2
Switches			
SW1	17	Front Door Safety	B2
SW2	42	Shift Tray Upper Limit	C6
Solenoids			
SOL1	4	Stapler Junction Gate	D6
SOL2	5	Tray Junction Gate	D6
SOL3	11	Pre-stack Junction Gate	E6
SOL4	16	Pre-stack Paper Stopper	E6
SOL5	15	Positioning Roller	E6
SOL6	26	Stapler Return	I6
PCBs			
PCB1	12	Main	K4
PCB2	6	Punch	J3

POINT TO POINT DIAGRAM (Finisher: B302)

